

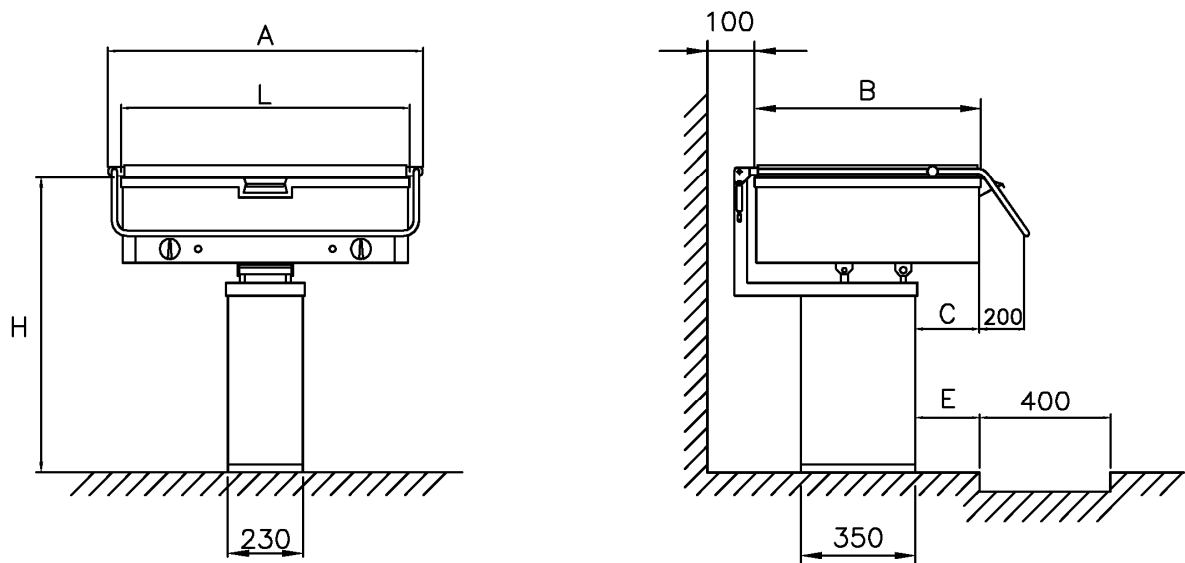

# Technical data for frying pan model J

## Dimensions and volume

On pillar



Model J with 65 mm deep pan

| Type  | A [mm] | B [mm] | C [mm] | L [mm] | H [mm] | Inner dimensions [mm] | Brim volume [l] | Weight* [kg] | IP-class |
|-------|--------|--------|--------|--------|--------|-----------------------|-----------------|--------------|----------|
| J-225 | 730    | 590    | 160    | 640    | 900    | 520x470x65            | 17              | 91           | X4       |
| J-425 | 915    | 640    | 210    | 825    | 900    | 705x520x65            | 25              | 120          | X4       |
| J-675 | 1150   | 640    | 210    | 1060   | 900    | 940x520x65            | 34              | 144          | X4       |

Model JD with 120 mm deep pan

| Type    | A [mm] | B [mm] | C [mm] | L [mm] | H [mm] | Inner dimensions [mm] | Brim volume [l] | Weight* [kg] | IP-class |
|---------|--------|--------|--------|--------|--------|-----------------------|-----------------|--------------|----------|
| J-225 D | 730    | 590    | 160    | 640    | 900    | 520x470x120           | 31              | 95           | X4       |
| J-425 D | 915    | 640    | 210    | 825    | 900    | 705x520x120           | 47              | 128          | X4       |
| J-675 D | 1150   | 640    | 210    | 1060   | 900    | 940x520x120           | 62              | 155          | X4       |

\* The weight can vary depending on the chosen accessory.

# Technical data for frying pan model J

On legs

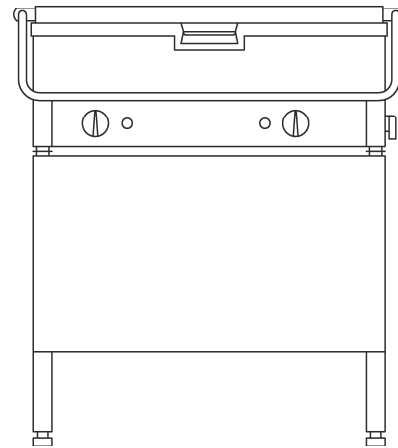
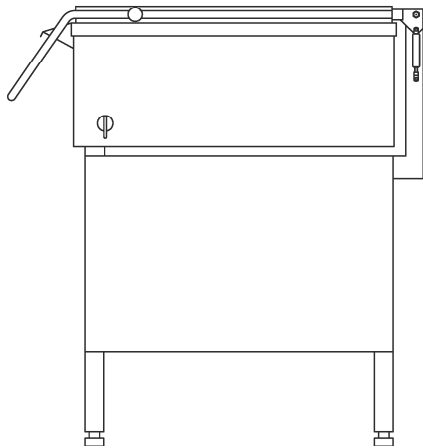

## Specifications for tilting frying pan J

3 sizes in 2 depth  
Pillar- or stand- mounted version  
Method of heating: Electric  
Number of heating zones: J-225: 1 zone, J-425 and J-675: 2 zones  
Temperature control: Thermostat  
Method for tilting: Electric  
Lid: Hinged or loos lid  
Heat adjustment: Steeples  
Rated power: According to table  
Max. Temperature: 250 C  
Pillar/stand and all outer surfaces: Stainless steel  
Pan: Standard steel  
Lid: Stainless steel  
Working height: 900 mm

## Accessory for model J

Height adjustable pan / stand with working height : 800 - 1000 mm  
Imbedding frame

# Technical data for frying pan model J

## Connections for Model J

| Type  | Effekt       | 3x230V+PE        |  | 3x400V+PE        |  |
|-------|--------------|------------------|--|------------------|--|
|       |              | Rated power [kW] | Current consumption [A] L <sub>1</sub> +L <sub>2</sub> +L <sub>3</sub> | Rated power [kW] | Current consumption [A] L <sub>1</sub> +L <sub>2</sub> +L <sub>3</sub> |
| J-225 | Normal power | 6,0              | 17/17/11   | 6,0              | 14/8/8   |
|       | High power   | 8,8              | 25/25/17   | 8,8              | 15/15/10   |
| J-425 | Normal power | 9,0              | 23/23/23   | 9,0              | 14/14/14   |
|       | High power   | 13,2             | 33/33/33   | 13,2             | 19/19/19   |
| J-675 | Normal power | 12,0             | 29/34/29   | 12,0             | 22/14/14   |
|       | High power   | 17,6             | 42/50/42   | 17,6             | 29/29/24   |

| Type  | Effekt       | 3x400V+N+PE      |  | 3x440V+PE        |  | 3x480V+PE        |  |
|-------|--------------|------------------|--|------------------|--|------------------|--|
|       |              | Rated power [kW] | Current consumption [A] L <sub>1</sub> +L <sub>2</sub> +L <sub>3</sub> | Rated power [kW] | Current consumption [A] L <sub>1</sub> +L <sub>2</sub> +L <sub>3</sub> | Rated power [kW] | Current consumption [A] L <sub>1</sub> +L <sub>2</sub> +L <sub>3</sub> |
| J-225 | Normal power | 6                | 13/7/7   | 5,5              | 11/6/6   | -                | -  |
|       | High power   | 8,8              | 19/10/10   | 8,1              | 16/9/9   | 8,8              | 9,2/4,6/4,6  |
| J-425 | Normal power | 9                | 13/13/13   | 8,3              | 11/11/11   | -                | -  |
|       | High power   | 13,2             | 19/19/19   | 12               | 16/16/16   | 13,2             | 9,2/9,2/9,2  |
| J-675 | Normal power | 12               | 20/20/13   | 11               | 17/11/17   | -                | -  |
|       | High power   | 17,6             | 29/29/19   | 16               | 24/16/24   | 17,6             | 20/24/20   |

# Technical data for frying pan model J

## Installation data for model J

Location of pillar, floor drain, electric connections and bolts

Dokument nr. 10000004115-000-04 Page 4/4

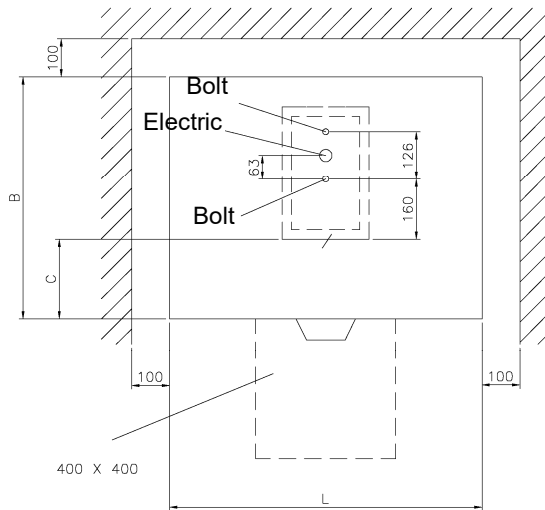

| Type  | A [mm] | B [mm] | C [mm] | L [mm] |
|-------|--------|--------|--------|--------|
| J-225 | 530    | 590    | 160    | 640    |
| J-425 | 530    | 640    | 210    | 825    |
| J-675 | 530    | 640    | 210    | 1060   |

Placement of the ombedding frame

