



Multi AutoTemp 32

Technical data

10000035839-TDA-000-00



The appliance can be shown with some accessory on the photo.

The control can be mounted either to the right or to the left of the kettle.

Multi AutoTemp 32, MultiMix AutoTemp 56 and MultiMix AutoChef 86 can be combined.

Heating directly with 1 bar steam pressure and the maximum temperature of 120°C.
Steam supply from an external steam generator, or build in electric steam generator.

Dimensions of the kettle and the mounting pillar

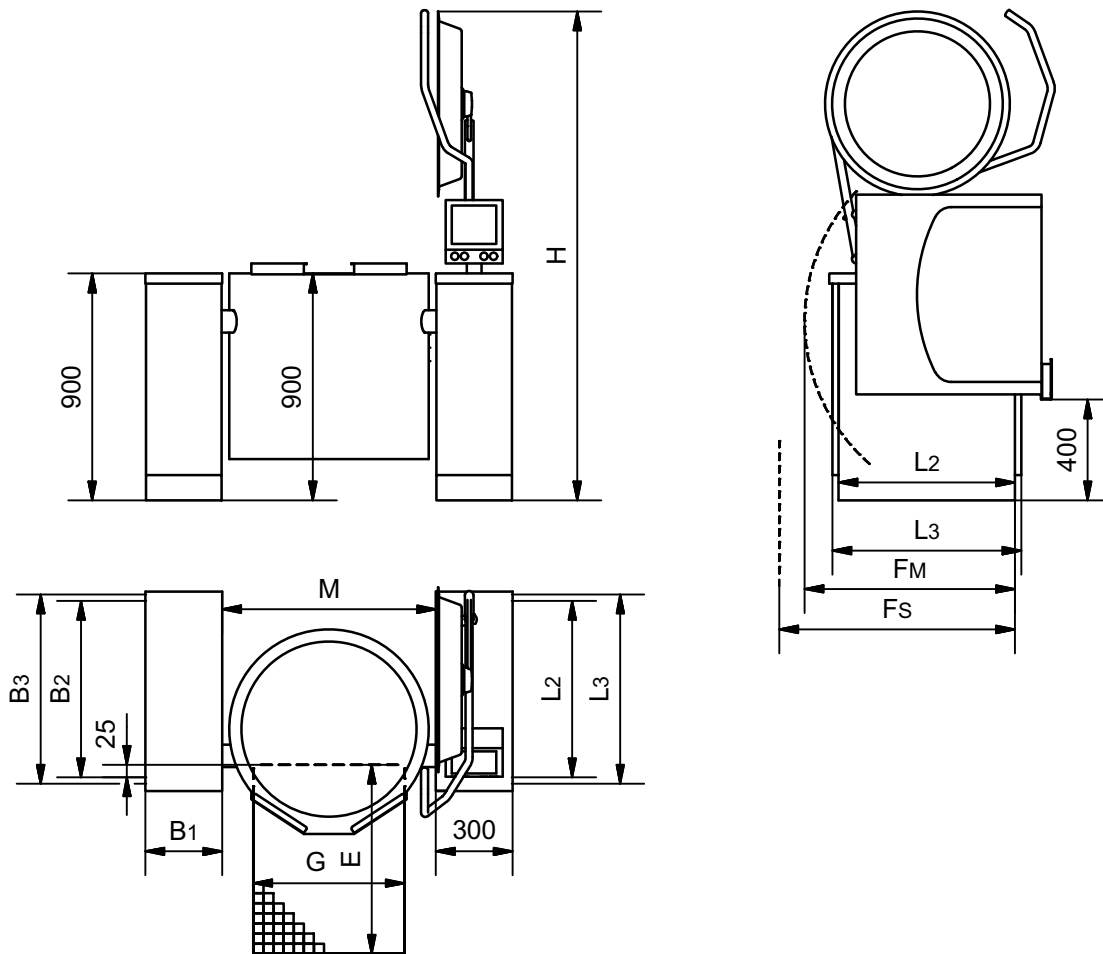

Size	L2/L3 [mm]	Fm [mm]	Fs [mm]	H [mm]	M [mm]	G [mm]	E* [mm]
Multi 40	500/550	640	800	1720	606	400	600
Multi 60	500/550	740	820	1770	655	400	600
Multi 80	500/550	790	880	1780	685	500	800
Multi 100	500/550	820	900	1810	735	500	800
Multi 120	500/550	880	980	1810	735	500	800
Multi 150	700/750	920	1000	1970	852	600	900
Multi 200	700/750	1000	1000	2020	902	600	900
Multi 250	700/750	1080	1080	2090	1000	600	900
Multi 300	700/750	1150	1150	2130	1100	600	900

Fm is the shortest distance to enable tilting the kettle. Fs is the shortest distance to enable service.

Bigger distance is recommended in consideration of service and the risk of crushing. National/local regulations must always be observed.

**For kettles with butterfly valves or drain valves, the content can run behind the floor drain when tilting with open valve. This can occur e.g. when cleaning.*

It has to be considered to enlarge the drain cf. dimensions in the section 'Location of the drain valve'.

Dimensions of the support pillars for electric heated kettles.

Size	B1 [mm]	B2 [mm]	B3 [mm]	Fs [mm]
80 x 425 mm*	80	425	-	525
150 x 300 mm**	150	275	300	400
230 x 550 mm	230	500	550	700
300 x 550 mm	300	500	550	700
230 x 750 mm	230	700	750	900
300 x 750 mm	300	700	750	900
400 x 750 mm	400	700	750	900
500 x 750 mm	500	700	750	900

*Only for one kettle for maximal 120 L. Spray gun not an option.

** Spray gun not possible.

Fs is the shortest distance to enable service.

This must be compared with the Fs dimension for the kettle and the biggest Fs dimension must be used.

Dimensions for the support pillars for steam heated kettles

Kettles from the same model can be combined in pairs. The control is mounted in the outer pillars.

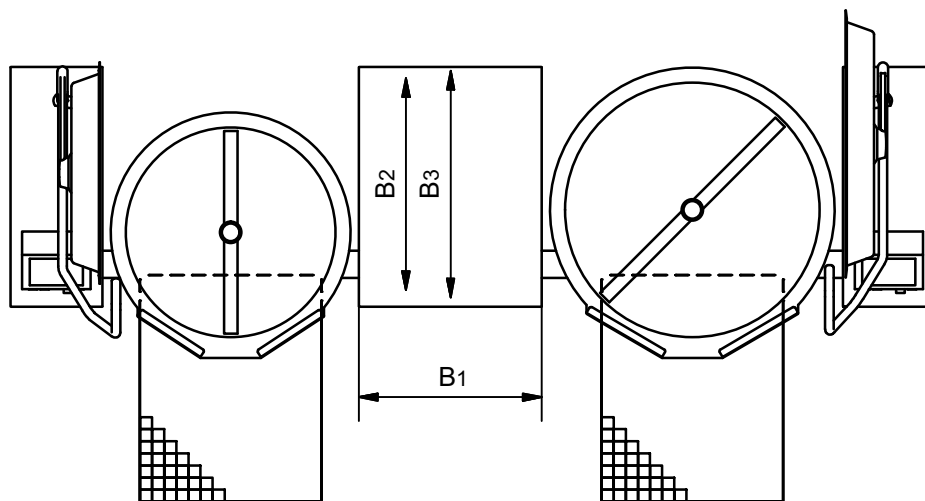

Type	B1 [mm]	B2 [mm]	B3 [mm]	Fs [mm]
One steam heated kettle No chilling	300	700	750	1100
Two steam heated kettles No chilling	500	700	750	1100
One steam heated kettle Chilling with water from the mains supply	400	700	750	1100
Two steam heated kettles Chilling with water from the mains supply	600	700	750	1100



F_s is the shortest distance to enable service.

This must be compared with the F_s dimension for the kettle and the biggest F_s dimension must be used.

Electric connection for electric heated kettels

In the users manual there is important information regarding supply and connections.

3~230V+PE, 50/60Hz

Size [l]	Power [kW]	Current consumption [A]	Time to boil 10-90°C [min]	Isc [kA] min/max
40	12	28/28/28	19	Max. 35A gG*
60	12	28/28/28	28	Max. 35A gG*
80	12	28/28/28	38	Max. 35A gG*
100	12	28/28/28	47	Max. 35A gG*
120	12	28/28/28	56	Max. 35A gG*
150	24	55/55/55	35	0,32/20
200	24	55/55/55	47	0,32/20
250	36	83/83/83	39	0,32/20
300	36	83/83/83	47	0,32/20

* largest allowed backup fuse.

3~400V+PE, 50/60Hz

Size [l]	Power [kW]	Current consumption [A]	Time to boil 10-90°C [min]	Isc [kA] min/max
40	15	22/22/22	15	Max. 35A gG*
60	15	22/22/22	23	Max. 35A gG*
80	15	22/22/22	30	Max. 35A gG*
100	20	29/29/29	28	Max. 35A gG*
120	20	29/29/29	34	Max. 35A gG*
150	30	43/43/43	28	0,25/10
200	30	43/43/43	38	0,25/10
250	45	65/65/65	31	0,25/10
300	45	65/65/65	38	0,25/10

* largest allowed backup fuse.



3~440V+PE, 50/60Hz

Size [l]	Power [kW]	Current consumption [A]	Time to boil 10-90°C [min]	Isc [kA] min/max
40	15	20/20/20	15	Max. 35A gG*
60	15	20/20/20	23	Max. 35A gG*
80	15	20/20/20	30	Max. 35A gG*
100	20	26/26/26	28	Max. 35A gG*
120	20	26/26/26	34	Max. 35A gG*
150	30	39/39/39	28	0,25/6
200	30	39/39/39	38	0,25/6
250	45	59/59/59	31	0,25/6
300	45	59/59/59	38	0,25/6

* largest allowed backup fuse.

Electric connection for steam heated kettles.

In the users manual there is important information regarding supply and connections.

3~230V+PE, 50/60Hz

Size [l]	Power [kW]	Current consumption [A]	Isc [kA] min/max
40	0,12	0,5/0,5/0	0,02/20
60	0,12	0,5/0,5/0	0,02/20
80	0,12	0,5/0,5/0	0,02/20
100	0,12	0,5/0,5/0	0,02/20
120	0,12	0,5/0,5/0	0,02/20
150	0,12	0,5/0,5/0	0,02/20
200	0,12	0,5/0,5/0	0,02/20
250	0,12	0,5/0,5/0	0,02/20
300	0,37	1,1/1,1/1,1	0,06/20



3~400V+PE, 50/60Hz

Size [l]	Power [kW]	Current consumption [A]	Isc [kA] min/max
40	0,12	0,3/0,3/0	0,02/10
60	0,12	0,3/0,3/0	0,02/10
80	0,12	0,3/0,3/0	0,02/10
100	0,12	0,3/0,3/0	0,02/10
120	0,12	0,3/0,3/0	0,02/10
150	0,12	0,3/0,3/0	0,02/10
200	0,12	0,3/0,3/0	0,02/10
250	0,12	0,3/0,3/0	0,02/10
300	0,37	0,7/0,7/0,7	0,6/10

3~440V+PE, 50/60Hz

Size [l]	Power [kW]	Current consumption [A]	Isc [kA] min/max
40	0,12	0,3/0,3/0	0,02/6
60	0,12	0,3/0,3/0	0,02/6
80	0,12	0,3/0,3/0	0,02/6
100	0,12	0,3/0,3/0	0,02/6
120	0,12	0,3/0,3/0	0,02/6
150	0,12	0,3/0,3/0	0,02/6
200	0,12	0,3/0,3/0	0,02/6
250	0,12	0,3/0,3/0	0,02/6
300	0,37	0,6/0,6/0,6	0,06/6

Energy efficiency

The kettels have an energy efficiency of 95%, measured by the EFCEM's standard.

The measurements are made with 400V supply, voltage but depending on the actual supply voltage, accessory, size, ect. energy efficiency may differ slightly.

Water

In the users manual there is important information regarding supply and connections.

Water	Pressure [bar]	Amount [l/min]	Temperature [°C]
Cold	1,5-6	35	-
Hot	1,5-6	35	< 60

Hot water is only used when the kettle is equipped with a spray gun or the possibility to use hot water in the kettle.



Volume

Size [l]	Net [l]	Gross [l]	Diameter [mm]	Depth [mm]
40	40	48	452	337
60	60	70	501	397
80	80	91	531	455
100	100	113	581	475
120	120	133	581	552
150	150	169	700	494
200	200	222	750	561
250	250	278	850	556
300	300	334	950	545

Weight

Size	Transportation weight* [kg]	Weight in use** [kg]
Multi 40 AutoTemp 32	181	244
Multi 60 AutoTemp 32	193	283
Multi 80 AutoTemp 32	204	317
Multi 100 AutoTemp 32	216	356
Multi 120 AutoTemp 32	223	384
Multi 150 AutoTemp 32	261	474
Multi 200 AutoTemp 32	320	593
Multi 250 AutoTemp 32	371	717
Multi 300 AutoTemp 32	415	836

* 'Transportation weight' includes a support pillar in the same dimensions as the control pillar. The weight is without water in the steam generator and without accessory.

** 'Weight in use' includes a support in the same dimensions as the control pillar, a completely with water filled steam generator and the kettle filled by water to the brim. The weight is without accessory.



Ventilation

3~230V+PE, 50/60Hz

Size [l]	Sensible [W]	Latent [W]	Steam [kg/h]
40	420	2400	3,6
60	420	2400	3,6
80	420	2400	3,6
100	420	2400	3,6
120	420	2400	3,6
150	840	4800	7,1
200	840	4800	7,1
250	1260	7200	10,6
300	1260	7200	10,6

3~400V+PE / 3~440V+PE, 50/60Hz

Size [l]	Sensible [W]	Latent [W]	Steam [kg/h]
40	525	3000	4,4
60	525	3000	4,4
80	525	3000	4,4
100	700	4000	5,9
120	700	4000	5,9
150	1050	6000	8,8
200	1050	6000	8,8
250	1575	9000	13,2
300	1575	9000	13,2

The data is based on the German standard VDI 2052 for dimensioning of ventilation facilities.

The values are based on experience with an average product and a normal usage, and the actual demand varies by the efficiency of the appliance, the control and the way of use.

The simultaneity factor, which can be found in VDI 2052 is not taken into account.

Noise

Noise from the machine < 60 dB(A).

Steam

In the users manual there is important information regarding supply and connections.

Only for kettles heated by an external steam generator.

Size [l]	Steam consumption 10-90° (20 min.) [kg/h]
40	25
60	37
80	48
100	58
120	70
150	88
200	115
250	144
300	173

Compressed air

*In the users manual there is important information regarding supply and connections.
Only for kettles heated by an external steam generator.*

Size	Pressure [bar]	Amount [l/min]
All	7-8	0,5

Distance under the kettle

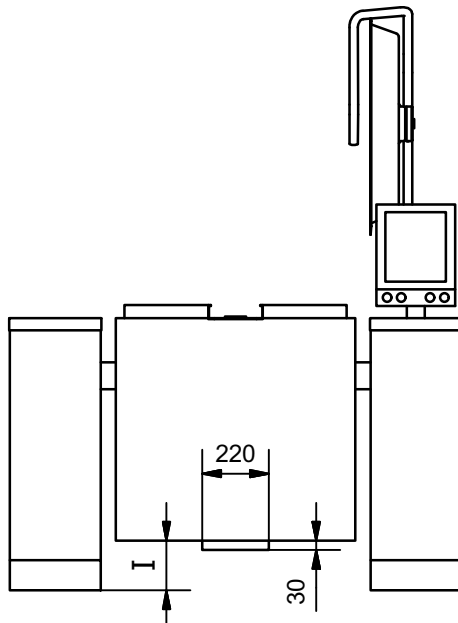

Size [l]	l [mm]
40	330
60	270
80	210
100	190
120	115
150	160
200	95
250	100
300	110

Location of the drain valve

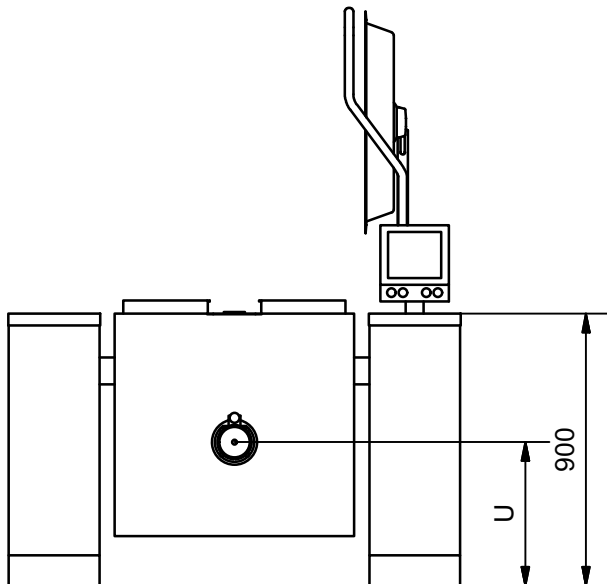

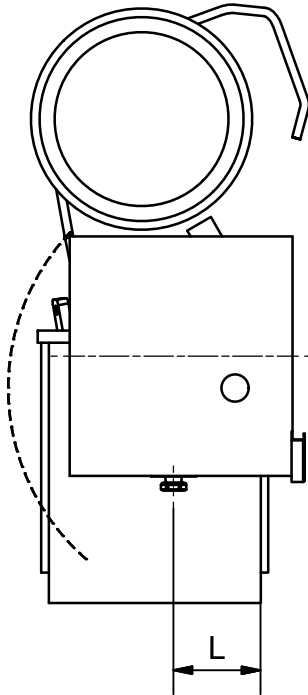

Size [l]	L [mm]	U [mm]
40	130	665
60	185	610
80	240	555
100	250	545
120	330	465
150	255	540
200	315	480
250	300	495
300	270	525

Additional equipment

Butterfly valve with drain downwards

The unit can be dismantled e.g. when cleaning, and a plug to close the pipe when the valves is not mounted is attached.

The angle is welded to the valve, providing a shorter construction.

2" ISO Clamp

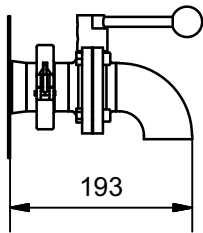

3" ISO Clamp

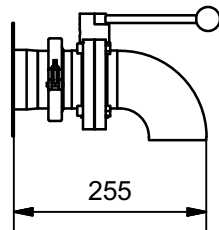

2" SMS

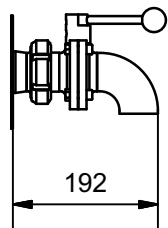

3" SMS

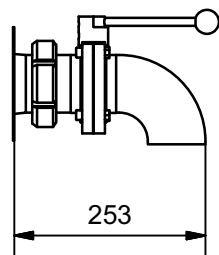

2" DS

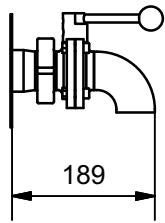

3" DS

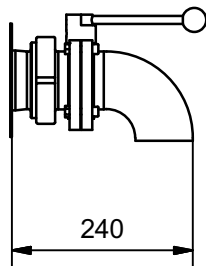

Butterfly valve with connection for a pump

This valve is suitable for connecting a pump to the kettle.

If an angle (accessory) is mounted, the valve can also be used without a pump. e.g. when cleaning.

The unit can be dismantled e.g. when cleaning, and a plug to close the pipe when the valves is not mounted is attached.

2" ISO Clamp

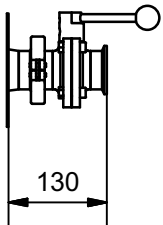

3" ISO Clamp

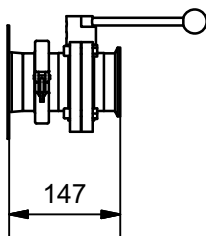

2" SMS

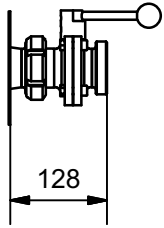

3" SMS

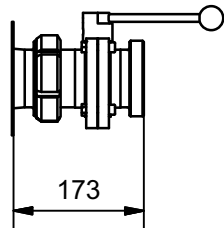

2" DS

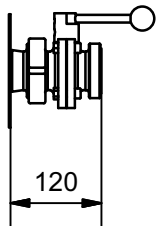

3" DS

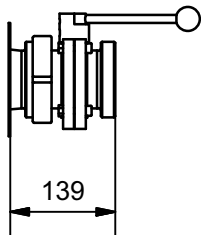

Angles for butterfly valve

Loose angle for 2" ISO Clamp butterfly valve

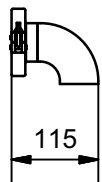

Loose angle for 3" ISO Clamp butterfly valve

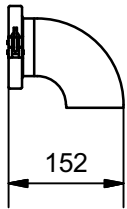

Loose angle for 2" SMS butterfly valve

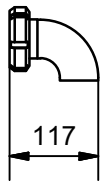

Loose angle for 3" SMS butterfly valve

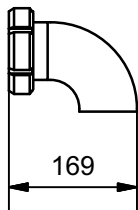

Loose angle for 2" DS butterfly valve

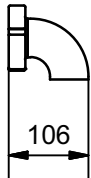

Loose angle for 3" DS butterfly valve

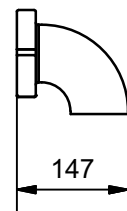

Drain tap, Echtermann type

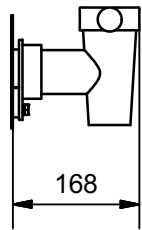

Outlet for customized solution

2" outlet

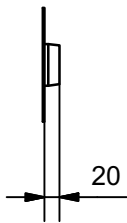

3" outlet

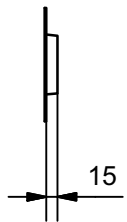

3" outlet with ISO Clamp

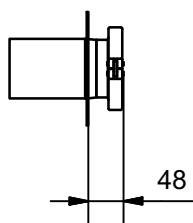

Trolley for accessory

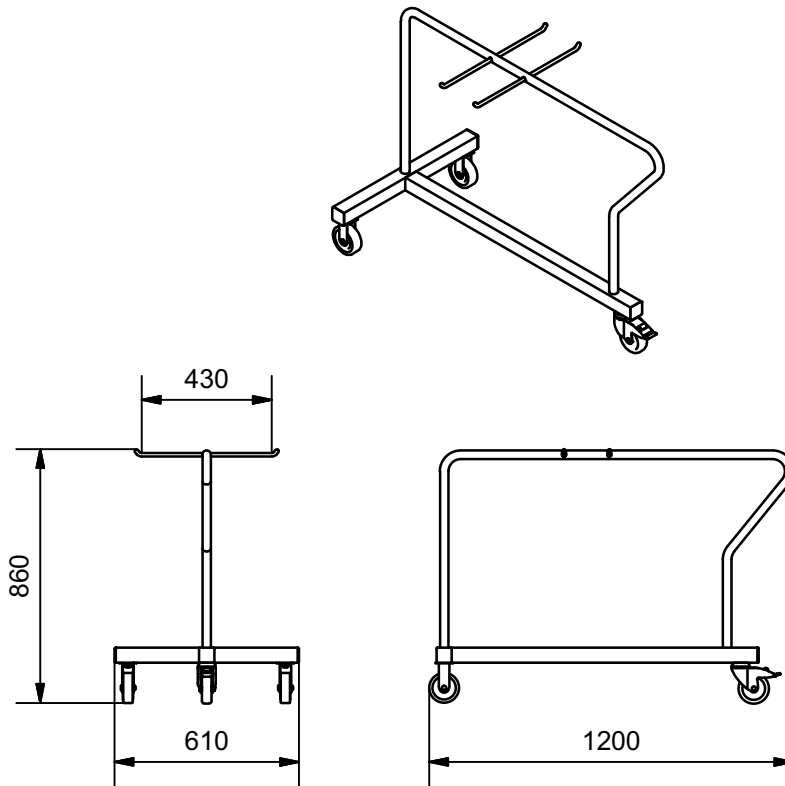

Wall bracket for accessory

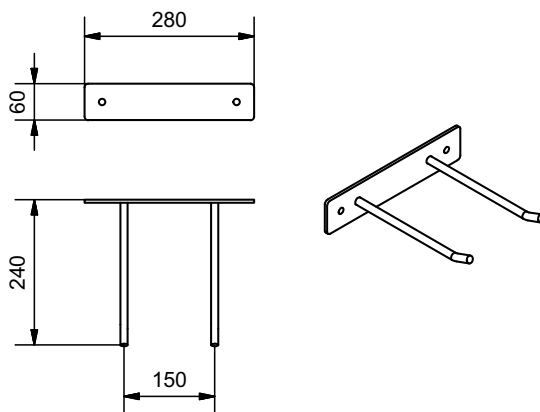

Jøni A/S reserve our right to alterations. Reservations against misprints.